

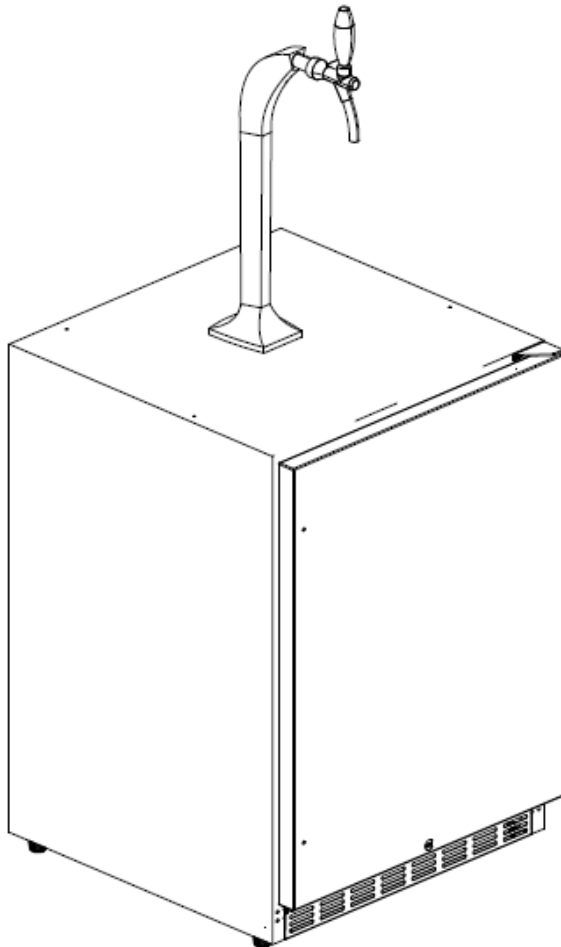

# INSTALLATION & OPERATING INSTRUCTIONS

MODEL #17900 KEGERATOR MANUAL



## TABLE OF CONTENTS

PAGE #

SAFETY INSTRUCTIONS .....	2
INSTALLATION INSTRUCTIONS .....	3
CABINET LOCATION GUIDELINES.....	3
CHANGING THE DOOR'S SWING.....	4
OPERATION INSTRUCTIONS.....	8
CONTROL PANEL.....	8
CARE AND MAINTENANCE.....	9
CLEANING YOUR APPLIANCE.....	9
POWER FAILURE .....	9
MOVING YOUR APPLIANCE.....	9
ENERGY SAVING TIPS.....	9
AUTOMATIC DEFROSTING OF THE KEGERATOR.....	10
TEMPERATURE / DOOR ALARM .....	10
TROUBLESHOOTING.....	11
PARTS LIST.....	12
EXPLODED ILLUSTRATION.....	13
TOWER/ REGULATOR PARTS LIST.....	14
EXPLODED ILLUSTRATION.....	15
LIMITED WARRANTY.....	16
REGISTERING YOUR KEGERATOR.....	16

- READ THE FOLLOWING INSTRUCTIONS CAREFULLY AND BE SURE YOUR KEGERATOR IS PROPERLY INSTALLED, ASSEMBLED AND CARED FOR. FAILURE TO FOLLOW THESE INSTRUCTIONS MAY RESULT IN SERIOUS BODILY INJURY AND/OR PROPERTY DAMAGE. IF YOU HAVE QUESTIONS CONCERNING ASSEMBLY OR OPERATION, CONSULT YOUR DEALER OR APPLIANCE SERVICE REPRESENTATIVE.

**- NOTE TO INSTALLER:**

LEAVE THESE INSTRUCTIONS WITH THE CONSUMER AFTER INSTALLATION.

**- NOTE TO THE CONSUMER:**

RETAIN THESE INSTRUCTIONS FOR FUTURE REFERENCE.

\*FOR WARRANTY PURPOSES, PLEASE RECORD YOUR SERIAL NUMBER, DATE OF PURCHASE & A COPY OF YOUR RECEIPT OR INVOICE IN THE BACK OF YOUR MANUAL ON PAGE 11.



# SAFETY INSTRUCTIONS

## READ CAREFULLY BEFORE OPERATION OF YOUR KEGERATOR

### ATTENTION:

- To minimize shock and fire hazards, be sure not to overload outlet. Please designate one outlet for your unit.
- Do not use extension cords.
- Do not put your hands under the unit when the unit is required to be moved.
- When the unit is not in use for a long period of time, please unplug the unit from the outlet.
- After unplugging the unit, wait at least 10 minutes before re-plugging it. Failure to do so could cause damage to the compressor.
- Do not defrost the appliance with other electric appliances (for example a hair dryer) and never attempt to scrape/remove ice/frost with sharp objects.

### UNPLUG CORD:

- To minimize shock and fire hazards, please do not plug or unplug the cord with wet hands.
- During maintenance and cleaning, please unplug the unit.

### PROPER GROUNDING REQUIRED:

- To minimize shock and fire hazards, make sure that the unit is properly grounded.

### PROHIBITED:

- Do not attempt to remove or repair any component unless instructed by factory.
- Make sure that the unit is not resting on or against the electrical cord and plug.
- To minimize personal injury, do not hang on the door.
- Do not store any flammable and explosive gas or liquids inside the unit.
- Do not attempt to alter or tamper with the electrical cord.

# INSTALLATION INSTRUCTIONS

## READ CAREFULLY BEFORE INSTALLATION OF YOUR KEGERATOR

- If the unit has recently been transported, please let unit stand still for a minimum of 24 hours before plugging it in.
- Make sure that the unit drops down to desired temperature before loading the unit with product.
- Make sure that there is proper ventilation around the unit in the area where it will operate.
- Make sure all accessories are installed, if necessary, before plugging the unit in.

### ***CABINET LOCATION GUIDELINES***

- Install the unit on strong and leveled surfaces.
  - Unit may make unpleasant noises if surface is uneven.
  - Unit may malfunction if surface is uneven.
- Install the unit in a dry, well-ventilated area.
  - Unit should be away from direct sunlight; extreme cold ambient temperatures may also cause the unit not to perform properly.
- Avoid installation in a high humidity and/or dusty area.
  - Humidity could cause unit to rust and decrease efficiency of the unit.
  - Dust collected on condenser coil will cause unit to malfunction. Clean the condenser at least once a month with a brush or clean cloth.
- Avoid placing the unit near heat emitting devices (for example cooking appliances, radiators, water heaters, or similar devices) and moisture-generating equipment.
  - High ambient temperatures will cause the compressor to overwork, leading to higher energy bills and gradual breakdown of the unit.
- The unit must have more than 20 cm of clearance from the cabinet to any walls.
  - Since this product has many ventilation holes underneath, please make sure there is a gap of at least 3 cm between the bottom of the product and the ground. Also make sure there is nothing stuck underneath.

## REVERSING THE DOOR SWING OF YOUR APPLIANCE

This unit has the capability of the door opening from either the left or right side. The unit is delivered to you with the door opening from the left side. Should you desire to reverse the opening direction, please follow the reversal instructions shown below.

**NOTE:** All parts removed must be saved to allow the door swing to be reversed.

### Door parts

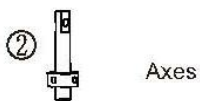

### Included parts



**1**

- A** Take out two hex keys from a bag in cabinet. Insert the small hex key ① to the axes ②.
- B** Rotating the axes ② by clockwise.
- C** Use the big hex key ③ to push the pin ④ until you can take out the pin by hand.

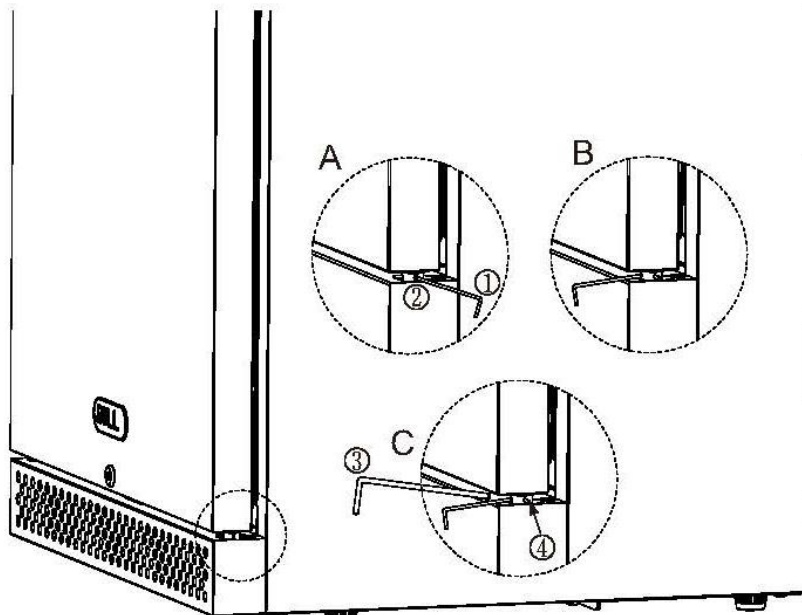

2

- Remove the top right screws ⑤ from right top hinge ⑥. Gently pull down the door and place it on a padded surface to avoid the risk of damage.
- Transfer the top left screws ⑦ to cover the top right holes.

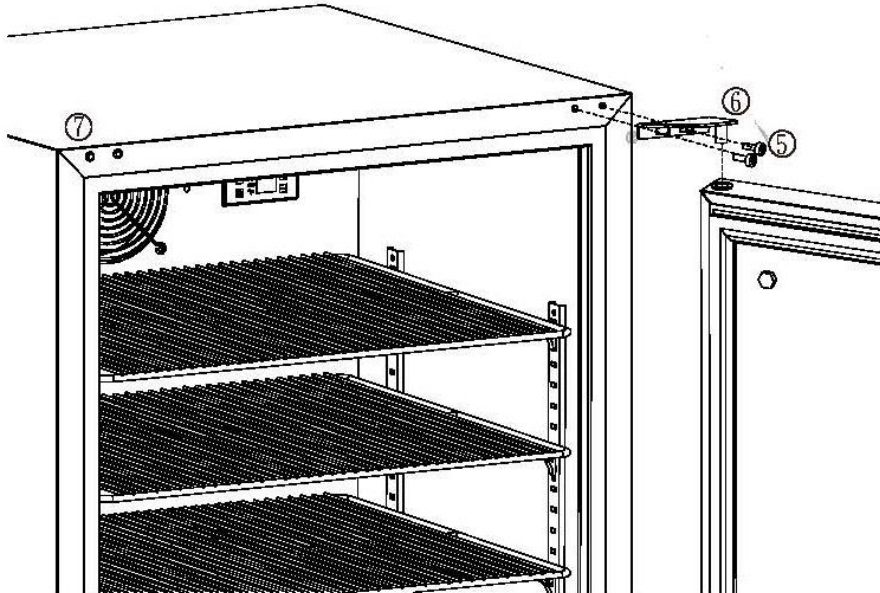

3

- To hang the axes ② to the opposite and put the caps ⑧ and ⑨ to cover the holes ⑩ and ⑪ at the same time.

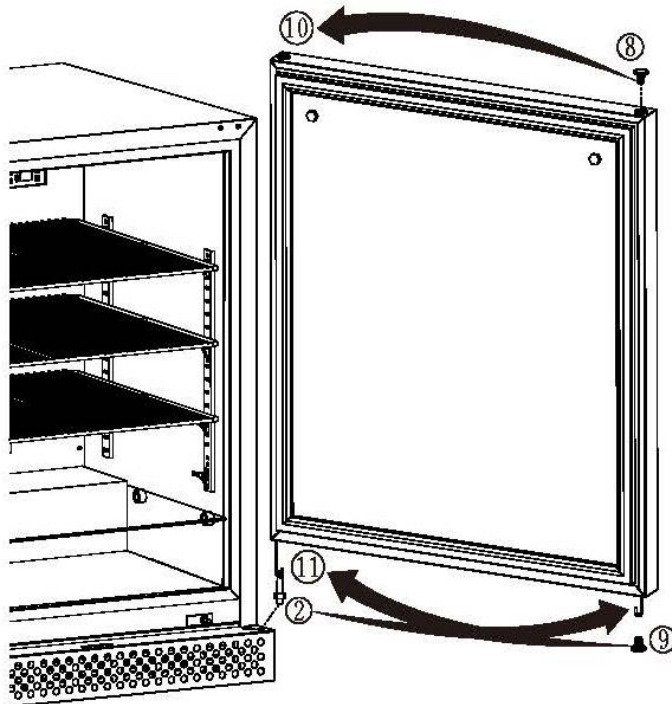

4

- Place the axes ② on the left hinge plate.

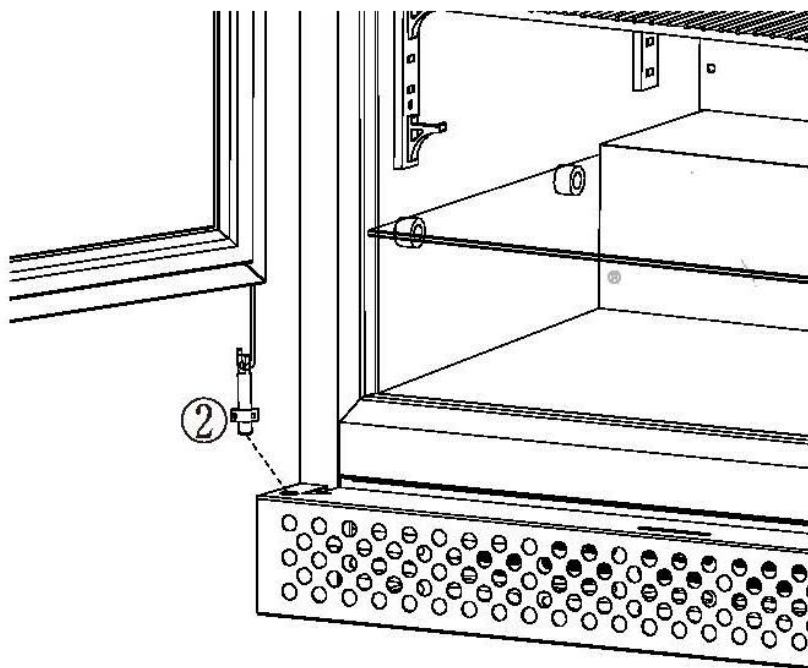

5

- Screw the alternative left top hinge ⑫, included in the fitting, onto the left hand side of cabinet and tighten it after the door is leveled.

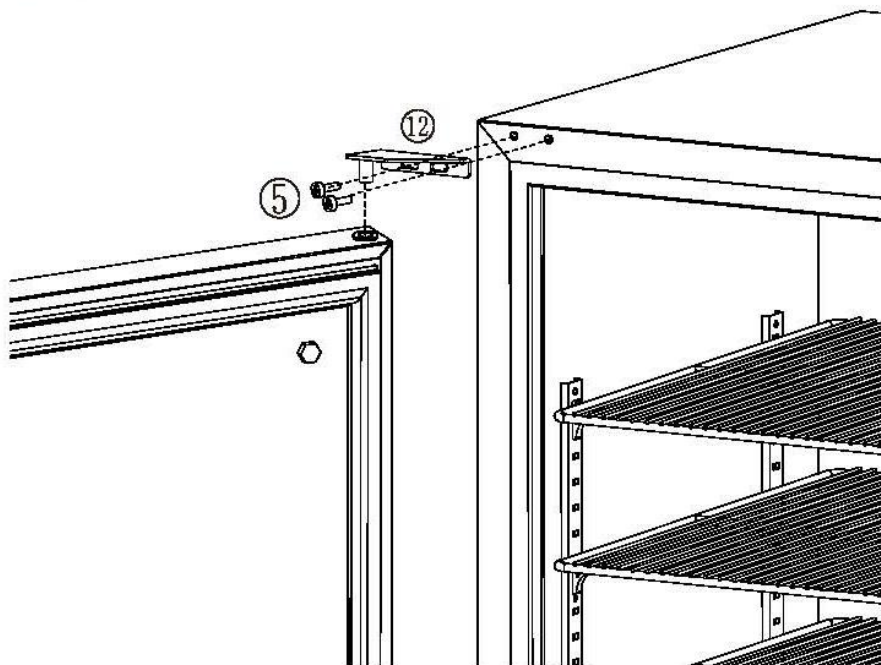

6

- A Use the small hex key ① to rotate the axes ② anticlockwise.
- B Insert the pin ④ when you get the desired intensity for self-closing.

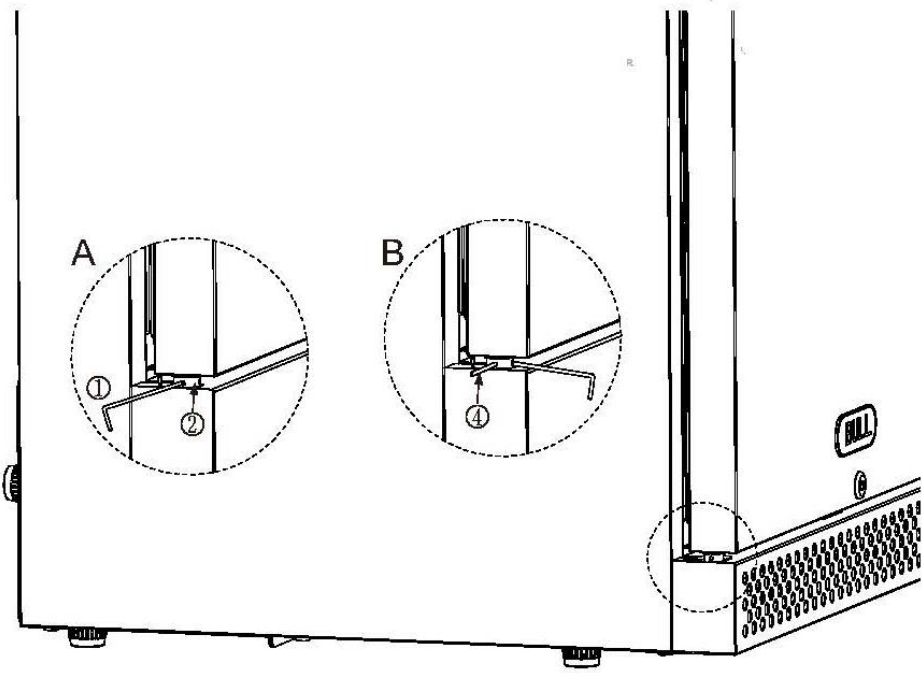





## OPERATING YOUR APPLIANCE

It is recommended that you install the appliance in a place where the ambient temperature is between 50° and 109.4°F (10°C- 43°C). If the ambient temperature is above or below recommended temperatures, the performance of the unit may be affected. For example, placing your unit in extremely cold or hot conditions may cause interior temperatures to fluctuate. The operating temperature range may not be reached.

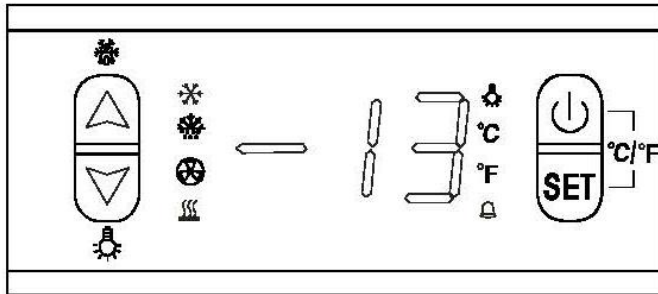

### CONTROL PANEL



### ON/OFF Power



To turn the appliance ON or OFF, press and hold the POWER key  for 5 seconds.

### UP and DOWN



Press  first, then press  or  button to increase (warm) or decrease (cool) the set temperature by 1°C/1°F.

Press  again, the temperature is selected and shows the actual temperature. If no other further operation in 6 seconds, display will show actual temperature in the cooler.

### °C/°F Selector

Selects the temperature display setting in Fahrenheit or Celsius degrees. To change the temperature from Fahrenheit to Celsius or from Celsius to Fahrenheit, press  and  at the same time, then hold for 6 seconds.

### Setting the Temperature Control

The temperature you are setting will increase by one degree each time you press the  key, and will decrease by one degree each time you press the  key.

The range of the temperature control is from 23°F to 68°F.

To view the set temperature at any time, press the  key. The set temperature will flash in the display window for 6 seconds. After 6 seconds, the temperature inside the unit will reappear in the display window.

(The temperature preset at the factory is 34°F).

## CARE AND MAINTENANCE

### CLEANING YOUR APPLIANCE

Turn off the power, unplug the appliance, and remove all items, including shelves.

Wash the inside surfaces with a solution of warm water and baking soda (about 2 tablespoons of baking soda to a quart of water).

Wash the shelves with a mild detergent solution.

Wring excess water out of the sponge or cloth when cleaning the area where the controls are located or any electrical parts.

Wash the outside cabinet with warm water and mild liquid detergent. Rinse well and wipe dry with a clean soft cloth.

Use an approved stainless steel cleaner to clean the door and handle. Do not use steel wool or a steel brush on the stainless steel.

#### **CAUTION:**

*Failure to unplug the appliance during cleaning could result in electrical shock or other personal injury.*

### POWER FAILURE

Most power failures are corrected within a few hours and should not affect the temperature of your appliance if you minimize the number of times the door is opened. If the power is going to be off for a longer period of time, you need to take the proper steps to protect the contents.

### VACATION TIME

**Short vacations:** Leave the appliance operating during vacations of less than three weeks.

**Long vacations:** If the appliance will not be used for several months, remove all items and turn off the appliance. Clean and dry the interior thoroughly. To prevent odor and mold growth, leave the door open slightly, blocking it open if necessary.

### MOVING YOUR APPLIANCE

1. Remove all items.
2. Securely tape down all loose items (shelves) inside your appliance.
3. Turn the adjustable legs up to the base to avoid damage.
4. Tape the door shut.
5. Be sure the appliance stays secure in the upright position during transportation. Also protect the outside of the appliance with a blanket or similar item.

### ENERGY SAVING TIPS

The appliance should be located in the coolest area of the room or outdoor location, away from heat-producing appliances and out of direct sunlight.

Ensure that the unit is adequately ventilated. Never cover air vents.

Do not keep the door open any longer than necessary.

Let hot foods cool to room temperature before placing in the unit. Overloading the unit forces the compressor to run longer.

Be sure to wrap foods properly, and wipe containers dry before placing them in the unit. This cuts down on frost build up inside the unit.

Unit shelves and storage bins should not be lined with aluminum foil, wax paper or paper toweling. Liners interfere with cold air circulation, making the unit less efficient.

Organize and label stored items to reduce door openings and extended searches. Remove as many items as needed at one time, and close the door as soon as possible.

### **Interior Light**

The unit is equipped with an interior LED light which will be turned ON when the door is open. And the interior fan is stopped at the same time. You can press  manually to turn on or turn off the light.

### **DEFROSTING**

The unit defrosts automatically in normal operating conditions.

The evaporator behind the rear wall of the unit defrosts automatically. The condensate collects in the drainage channel behind the rear wall of the unit, and flows through the drainage hole into the drip tray by the compressor where it evaporates.

However, frost may accumulate on the evaporator if the unit is repeatedly opened in a high heat or high humidity location. If this frost pattern does not clear within 24 hours, your unit will require manual defrosting.

Press  and hold for 6 seconds, the unit will be defrosted.

To stop defrost, please repeat the same interaction.

### **TEMPERATURE ALARM / DOOR ALARM**

An audible alarm sounds if the storage temperature is not cold enough. The temperature display flashes at the same time.

The cause of the temperature being too high may be:

- Warm fresh food was placed inside
- Too much warm ambient air flowed in when rearranging and removing stored items
- Power failure for some time
- The appliance is faulty

The audible alarm is automatically silenced and the temperature display stops flashing when the temperature is sufficiently cold again.

If the door has been left open for more than 60 seconds, the alarm will sound. Pressing any key once can switch off the audible alarm.

### **DOOR LOCK**

Your unit is provided with a lock and key combination.

The keys are located inside the plastic bag that contains the *Instruction Manual*. Insert the key into the lock and turn it counter-clockwise to unlock the door. To lock the door, do the reverse operation, making sure the metal pin is engaged completely. Remove the key and put it in a secure place for safekeeping.

### **PREPARATION**

**Position the Shelf-Supports inside the racks on the sides as illustrated below, at your required level, and then place the shelves firmly on the supports.**

### **SHELVES**

To prevent damaging the door gasket, make sure to have the door all the way open when pulling the shelves out of the Shelf-Supports.

Any of the shelves can be removed to store larger items. When removing the shelf out of the Shelf-Supports, make sure to remove all items first.

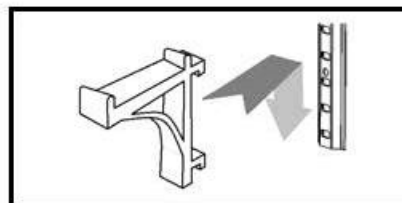

# TROUBLESHOOTING

There are many common issues you may experience with your Kegerator that can be solved easily, without a service call. Try the tips below to troubleshoot your unit should you experience any problems:

<b>SYMPTOM</b>	<b>POSSIBLE CAUSE</b>	<b>CORRECTIVE ACTION</b>
Compressor not running.	Fuse blown or circuit breaker tripped.	Replace fuse or reset circuit breaker.
	Power cord unplugged.	Plug in power cord.
	Thermostat set too high.	Set thermostat to lower temperature.
Condensing unit runs for long periods of time.	Excessive amount of warm product placed in Kegerator.	Allow adequate time for product to cool down.
	Prolonged door opening or door ajar.	Ensure door is closed when not in use. Avoid opening door for long periods of time.
	Door gasket(s) not sealing properly.	Ensure gaskets are snapped in completely. Remove gasket and wash with mild soap and warm water.
	Dirty condenser coil.	Clean the condenser coil.
	Evaporator coil iced over.	Unplug unit and allow coil to defrost. Make sure thermostat is not set too cold. Ensure that door gasket(s) are sealing properly.
Kegerator temperature is too warm.	Thermostat set too warm.	Set thermostat to lower temperature.
	Blocking air flow.	Re-arrange product to allow for proper air flow. Make sure there is at least four inches of clearance from evaporator.
	Excessive amount of warm product placed in Kegerator.	Allow adequate time for product to cool down.
	Fuse blown or circuit breaker tripped.	Replace fuse or reset circuit breaker.
	Dirty condenser coil.	Clean the condenser coil.
Kegerator is noisy.	Prolonged door opening or door ajar.	Ensure door is closed when not in use. Avoid opening door for long periods of time.
	Evaporator coil iced over.	(See above)
	Loose part(s).	Locate and tighten loose part(s).
	Tubing vibration.	Ensure tubing is free from contact with other tubing or components.

# PARTS LIST

## MODEL #17900 KEGERATOR

REF #	PARTS #	DESCRIPTION	QTY	WARRANTY PERIOD
1	17901	REAR COVER	1	1 yr
2	17902	COMPRESSOR COVER	1	1 yr
3	17903	DOOR	1	1 yr
4	17904	BOTTOM VENT	1	1 yr
5	13507	ADJUSTABLE FEET	4	1 yr
6	17905	TOP DOOR HINGE (RIGHT SIDE)	1	1 yr
6A	17906	TOP DOOR HINGE (LEFT SIDE)	1	1 yr
7	17907	BOTTOM DOOR HINGE	1	1 yr
8	17913	BEER TOWER	1	1 yr
9	17910	BEER FAUCET	1	1 yr
10	13706	SHELF LADDER	4	1 yr
11	13704	SHELF CLIP	12	1 yr
12	13707	SHELF	3	1 yr
13	17919	CAP	1	1 yr

### HOW TO ORDER REPLACEMENT PARTS

Please refer to the parts list on this page.

To make sure you obtain the correct replacement parts for your Kegerator, the following information is required to assure getting the correct part.

1. Reference number of replacement part needed.
2. Description of replacement part needed.
3. Quantity of parts needed.

**IMPORTANT:** Use only factory authorized parts. The use of any part that is not factory authorized can be dangerous. This will also void your warranty.

**IMPORTANT:** Keep this installation and operating instruction manual for referral, and for replacement parts ordering.



# EXPLODED ILLUSTRATION

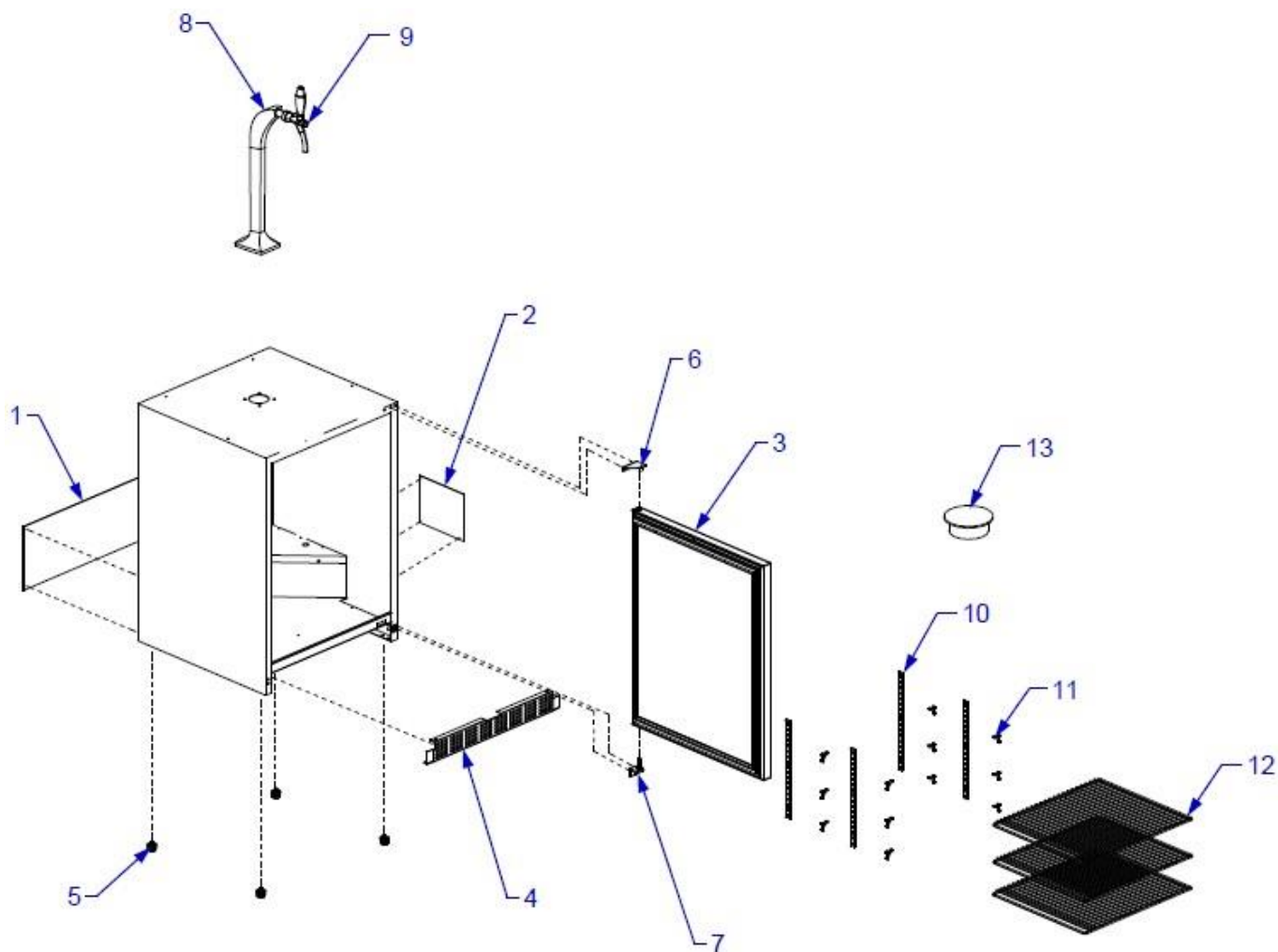

# TOWER/ REGULATOR PARTS LIST

## MODEL #17900 KEGERATOR

REF #	PART #	Description	QTY	WARRANTY PERIOD
1A	17911	BEER FAUCET HANDLE	1	1 yr
1B	17910	BEER FAUCET	1	3 yrs
2	17913	BEER TOWER	1	3 yrs
3	17912	SANKE D KEG COUPLER	1	3 yrs
4	17914	CO2 REGULATOR	1	1 yr
5	17915	CO2 CYLINDER	1	1 yr
6	17916	HOSE CLAMP	2	1 yr
11	17921	RUBBER MOUNTING WASHER	1	1 yr
12	17922	LARGE FLAT WASHER	1	1 yr
13	17923	MOUNTING NUT	1	1 yr
14	17924	1/4" BARBED NIPPLE	1	1 yr
15	17925	NUT	1	1 yr
16	17926	CLEAR RUBBER CHECK VALVE	1	1 yr
17	17927	1/4" BEER TUBE (CLEAR)	1	1 yr
18	17928	5/16" CO2 HOSE (RED)	1	1 yr
19A	17930	BEER CATCH - SCREEN	1	1 yr
19B	17931	BEER CATCH - TRAY	1	1 yr
20	17932	SPANNER WRENCH	1	1 yr
21	17933	FAUCET COLLAR	1	3 yrs
22	17934	RUBBER WASHER	1	1 yr
	13509	KEGERATOR KEY	1	1 yr

### HOW TO ORDER REPLACEMENT PARTS

Please refer to the parts list on this page.

To make sure you obtain the correct replacement parts for your Kegerator, the following information is required to assure getting the correct part.

1. Reference number of replacement part needed.
2. Description of replacement part needed.
3. Quantity of parts needed.

**IMPORTANT:** Use only factory authorized parts. The use of any part that is not factory authorized can be dangerous. This will also void your warranty.

**IMPORTANT:** Keep this installation and operating instruction manual for referral, and for replacement parts ordering.



# EXPLODED ILLUSTRATION

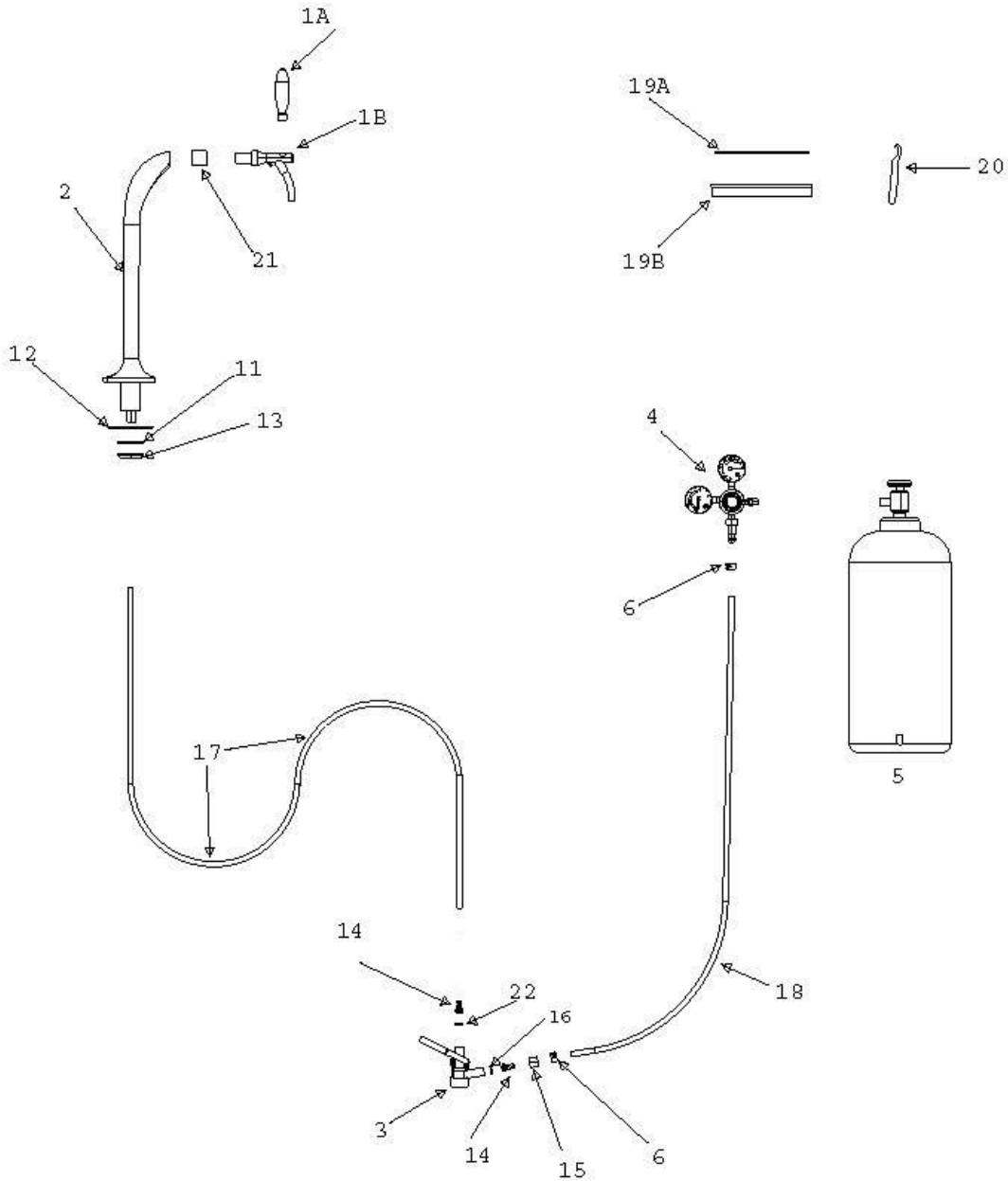



# 1 YEAR LIMITED WARRANTY

## REGISTERING YOUR KEGERATOR

In order to validate your Bull Limited Warranty, you must complete the Warranty Registration Card within 90 days from the Proof of Purchase. You may register your unit either online at [www.bullbbq.com](http://www.bullbbq.com) or by sending in the completed hard copy along with a copy of the Proof of Purchase to:

Product Registration  
Bull Outdoor Products  
2483 W Walnut Ave  
Rialto, CA 92376

Bull Outdoor Products, Inc. warrants to the original purchaser at the original site of delivery with proof of purchase of each Kegerator that when subject to normal residential use, it is free from defects in workmanship and materials for the periods specified below. This warranty excludes Kegerators used in rental or commercial applications. It does not cover labor or labor related charges. There will be a shipping and handling charge for the delivery of the warranty part(s).

Our obligation under this warranty is limited to repair or replacement, at our option, of the product during the warranty period. The extent of any liability of Bull Outdoor Products, Inc., under this warranty is limited to repair or replacement. This warranty does not cover normal wear of parts, damage resulting from any of the following: negligent use or misuse of the product, use contrary to operating instructions or alteration by any person other than our factory service center. The warranty period is not extended by such repair or replacement.

**Warranty claim procedure:** If you are filing a Warranty Claim, please visit our website at [Bullbbq.com](http://Bullbbq.com) and complete a Warranty Claim Form. The claim form can be located under the Support Tab, then Grill Warranty Claim Form. All claims **MUST** be submitted through the form in order to be processed. If you need further assistance, you may contact our Warranty Service Center during the hours of 5:00am to 5:00pm P.S.T. Monday through Friday, except holidays, at (800) 521-2855. The serial number is located on the back of the Kegerator.

Product repair as provided under this warranty is your exclusive remedy. Bull Outdoor Products, Inc. shall not be liable for any incidental or consequential damages for breach of any express or implied warranty on its products. Except to the extent prohibited by applicable law, any implied warranty or merchantability or fitness for a particular purpose on this product to the duration of the above warranty. Some states do not allow the exclusion or limitation of incidental or consequential damages, or allow limitations on how long an implied warranty lasts, so the above limitations or exclusions may not apply to you. This warranty gives you specific legal rights, and you may have other rights, which vary from state to state.

**Model Number** \_\_\_\_\_

**Serial Number** \_\_\_\_\_

**Date of Purchase** \_\_\_\_\_

**\*Attach a copy of your receipt or invoice here\***

